

POWER MANAGEMENT

Single 2A High-Side Power Switch

- Intelligent current limiting for capacitive load switching
- Current limit fault flag filter

The IMP2505 high-side switch family controls voltages from 2.7V to 7.5V and delivers at least 2A of continuous current. An open-drain fault flag indicates overcurrent limiting, open-load detection, thermal shutdown or undervoltage lockout.

The switches control loads with high inrush current without triggering a false overcurrent fault flag. Current faults do not set the fault flag unless the input-to-output differential is less than 250mV. This eliminates unwanted flags while driving capacitive loads. In addition, an overcurrent condition must be present for typically 12ms before the fault flag is set. Intelligent current limiting makes the IMP2505 ideal for Universal Serial Bus ganged port power management. The improved overcurrent protection does not require external resistors.

Other protection features include undervoltage lockout and thermal shutdown. The IMP2505 and IMP2505-3 have open-load detection capability. Open load detection is active when the switches are off. An open load triggers a fault flag.

Undervoltage lockout shuts off the switch if the supply voltage drops below 2.3V and turns on the switch after the supply exceeds 2.7V.

The IMP2505, IMP2505-1 and IMP2505-2 are improved, pin-for-pin replacements for the Micrel MIC2505/-1/-2 high side switches.

Key Features

- ◆ Intelligent Current Limiting
 - 12ms current limit fault flag filter
 - Masked current limit fault for capacitive load charging
- ◆ Low Resistance Power Switch
 - 30mΩ typical at 5V
 - 35mΩ typical at 3.3V
- ◆ Wide Input Voltage: 2.7V to 7.5V
- ◆ Low ON-state Supply Current: 110μA typical
- ◆ Low Power Off-state Supply Current
 - 0.75μA typical
- ◆ On-chip Protection
 - Current limiting
 - Thermal shutdown
 - Undervoltage lockout (UVLO)
- ◆ Open Drain Fault Flag
- ◆ Logic Level Control/Enable Input
- ◆ Optimum Slow 5ms Turn-on and Fast Turn-off
- ◆ Two Package Options: 8-pin SO and 8-pin DIP
- ◆ Extended Operating Temperature Range:
 - 40°C to 85°C

Applications

- ◆ USB power distribution
- ◆ PC card inrush current limiting
- ◆ Hot plug-in power supplies
- ◆ Battery chargers
- ◆ Low voltage power distribution and management
- ◆ Distributes DC power

Typical Application

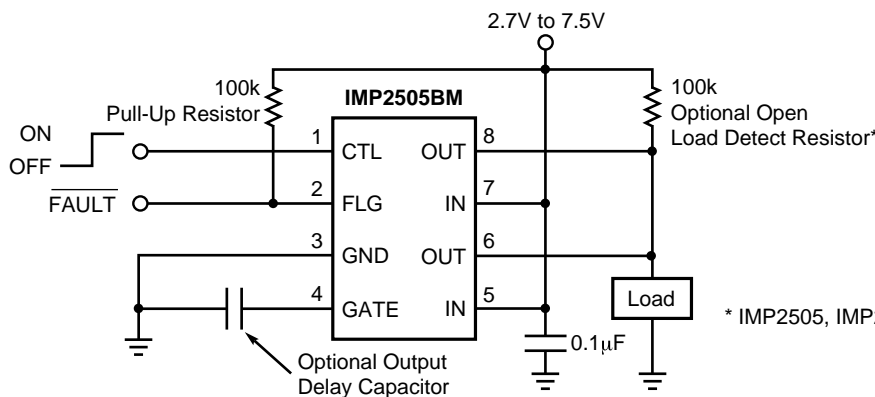

* IMP2505, IMP2505-3 only.

2505_01.eps

Pin Configuration

SO/DIP

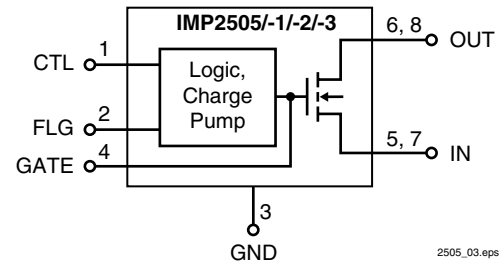
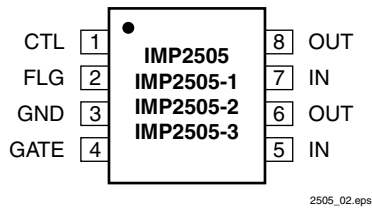

Pin Descriptions

Pin Number	Name	Function
1	CTL (A/B)	Control (Input): TTL compatible control input. High input typically > 1.8V. Low input typically < 1.6V. IMP2505, IMP2505-1 and IMP2506 are active HIGH. IMP2505-2 is active LOW.
2	FLG (A/B)	Fault Flag (Output): Active-LOW, open-drain output. If CTL is LOW, indicates open load. If CTL is HIGH, indicates current limit, thermal shutdown, or UVLO. IMP2505-1 and -2 do not support open-load detect.
3	GND	Ground.
4	GATE	Output MOSFET Gate: Open for fastest rise time. Connect capacitor to ground to slow rise time. (See IMP2505 Turn-On Delay graph)
5, 7	IN	Supply Input: Output MOSFET drain. Also supplies IC' s internal circuitry. Connect all IN pins together.
6, 8	OUT (A/B)	Switch Output: Output MOSFET source. Typically connect to switched side of load. Output voltage can be pulled above input voltage in off mode. Pins 6 and 8 must be externally connected together.

2505_102.eps

Ordering Information

Part Number	CTL Input Enable Logic	Open-Load Detection	Temperature Range	Pins-Package
IMP2505BM	Active-HIGH	Yes	-40°C to +85°C	8-SO
IMP2505BN	Active-HIGH	Yes	-40°C to +85°C	8-DIP
IMP2505-1BM	Active-HIGH	No	-40°C to +85°C	8-SO
IMP2505-1BN	Active-HIGH	No	-40°C to +85°C	8-DIP
IMP2505-2BM	Active-LOW	No	-40°C to +85°C	8-SO
IMP2505-2BN	Active-LOW	No	-40°C to +85°C	8-DIP
IMP2505-3BM	Active-LOW	Yes	-40°C to +85°C	8-SO
IMP2505-3BN	Active-LOW	Yes	-40°C to +85°C	8-DIP

2505_103.eps

For the 8-Pin SO package, add /T to the part number for tape and reel.

Selection Guide

Part Number	CTL Enable Logic Polarity	Open-Load Detection Function	Maximum ON Resistance (25°C)
IMP2505	Active-HIGH	Yes	50mΩ
IMP2505-1	Active-HIGH	No	50mΩ
IMP2505-2	Active-LOW	No	50mΩ
IMP2505-3	Active-LOW	Yes	50mΩ

2505_104.eps

Absolute Maximum Ratings

Supply Voltage	+8.0V
Fault Flag Voltage	+8.0V
Fault Flag Current (Intro Flag pin)	50mA
Output Voltage	+8.0V
Output Current	Internally Limited
Gate Voltage	$V_{IN} + 15V$
Control Input	-0.3V to 12V
Storage Temperature	-65°C to +150°C
Lead Temperature (Soldering, 5 sec.)	260°C

Operating Ratings

Supply Voltage	+2.7V to +7.5V
Ambient Operating Temperature	-40°C to +85°C
Package Thermal Resistance	
SOIC (θ_{JA})	160°C/W
DIP (θ_{JA})	105°C/W

Note: All voltages are referenced to GND.

These are stress ratings only and functional operation is not implied. Exposure to absolute maximum ratings for prolonged time periods may affect device reliability.

Electrical Characteristics

Unless otherwise noted, $V_{IN} = +5V$; GATE = Open and $T_A = 25^\circ C$. **Bold/blue** indicates $-40^\circ C \leq T_A \leq +85^\circ C$.

Parameter	Symbol	Conditions	Min	Typ	Max	Units
Supply Current	I_{CC}	IMP2505-1 $V_{CTL} = \text{Logic 0, OUT} = \text{open}$		0.75	5	μA
		IMP2505-2/-3 $V_{CTL} = \text{Logic 0, OUT} = \text{open}$ $V_{CTL} = \text{Logic 1, OUT} = \text{open}$		110 0.75	160 5	
Control Input Voltage	V_{IN}	$V_{CTL} = \text{Logic 0 to logic 1 transition}$ $V_{CTL} = \text{Logic 1 to logic 0 transition}$	0.8	2.1 1.9	2.4	V
Control Input Current	I_{IN}	$V_{CTL} = V_{OH(\min)} = 2.4V$ $V_{CTL} = V_{OL(\max)} = 0.8V$		0.01 0.01	1 1	μA
Control Input Capacitance				1		pF
Switch Resistance	R_{ON}	$V_{IN} = 5V, T_A = 25^\circ C$ $V_{IN} = 5V, -40^\circ C < T_A < +85^\circ C$ $V_{IN} = 3.3V, T_A = 25^\circ C$ $V_{IN} = 3.3V, -40^\circ C < T_A < +85^\circ C$		30 35	50 60 75	m Ω
Output Turn-On Delay	t_{DON}	$R_L = 10\Omega, C_{GATE} = 0$	200	850	2000	μs
Output Turn-On Rise Time	t_{RON}	$R_L = 10\Omega, C_{GATE} = 0$	500	3000	7500	μs
Output Turn-Off Delay	t_{DOFF}	$R_L = 10\Omega, C_{GATE} = 0$		0.7	20	μs
Output Turn-Off Rise Time	t_{RON}	$R_L = 10\Omega, C_{GATE} = 0$		1.5	20	μs
Output Leakage Current	I_{OFF}				10	μA
Current Limit Threshold			2	4		A
Current Limit Glitch Mask				12		ms
Enable Current-Limit Mask Trip Voltage	$V_{IN} - V_{OUT}$			250		mV
Open Load Threshold, Note 1		$V_{CTL} = \text{Logic low, Note 2}$	0.5	1	1.5	V
Overtemperature Shutdown		Increasing Junction Temperature		135		$^\circ C$
		Decreasing Junction Temperature		125		
Error Flag Output Resistance	R_{FLAG}	$V_{IN} = 5V, I_L = 10mA$		10	25	Ω
		$V_{IN} = 3.3V, I_L = 10mA$		15	40	
Error Flag Output Current	I_{FLAG}	$V_{FLAG} = 5V$		0.01	1	μA
UVLO Threshold	V_{UVLO}	V_{IN} Increasing	2.2	2.5	2.7	V
		V_{IN} Decreasing	2.0	2.3	2.5	

General Note: Devices are ESD protected, however, handling precautions recommended. All limits guaranteed by testing or statistical analysis.

Notes 1. IMP2505-1 and -2 versions do not have open-load detection. The IMP2505 and IMP2505-3 have open-load detection.

2. Open-load threshold is the output voltage (V_{OUT}) where FLG becomes active (LOW) when CTL is low. OUT is pulled high by a 100k Ω external resistor to V_{IN} .

Detailed Descriptions

The IMP2505 high-side, N-channel switches can switch 2A loads. Overcurrent limiting requires no external resistors. Undervoltage lockout and thermal protection circuitry protect the switches and system. The IMP2505 and IMP2505-3 have open-load detection capability.

Compared to competitive devices, all IMP2505 devices include performance enhancements. A current limit "glitch" filter masks the fault flag for current faults less than 12ms duration. In addition, when a switch is enabled (ON), the output must be within 250mV of the input before a current limit fault flag can be issued. This masking allows USB bus capacitors to be charged without generating a false overcurrent flag to the USB system controller.

Open-load detection is available on the IMP2505 (active HIGH enable input) and on the IMP2505-3 (active LOW enable input).

Overcurrent Limit and Current Limit Mask Operation

The current limit is preset internally and requires no external components. The preset current limit allows a minimum of 2A through the switch.

Overcurrent detection operates only when the output MOSFET is on, and the input voltage is above the undervoltage lockout threshold (UVLO). UVLO thresholds are typically 2.5V for V_{IN} rising and 2.3V for V_{IN} falling.

In addition, the FLG output is set by an overcurrent limit fault only if the output voltage is within typically 250mV of the input. This is an important feature in Universal Serial Bus applications. High capacitive output loads can be charged without initiating a current limit.

A current limit "glitch" filter insures that faults must be exist for typically 12ms before the FLG output is set.

Fault Flag Operation

FLG is an open-drain MOSFET output. The fault flag output is active LOW. The FLG output will typically sink 10mA at an output voltage of 100mV.

FLG is set LOW for any of the following conditions: current limit, open load (except the IMP2505-1 and IMP2505-2 which do not have open load detection), thermal shutdown or input undervoltage.

Control Input/Enable Input

If there are no fault conditions, the Control Input CTL turns the output MOSFET on. Devices are available with active-HIGH or active-LOW CTL levels:

Part Number	CTL Enable Logic Polarity
IMP2505	Active-HIGH
IMP2505-1	Active-HIGH
IMP2505-2	Active-LOW
IMP2505-3	Active-LOW

2505_105.eps

Thermal Shutdown

If the die temperature exceeds 135°C, the output MOSFET is turned off and the fault flag FLG is set. The switch will not turn on again until the die temperature falls to 125°C (10°C of hysteresis). Overtemperature detection operates only when the output MOSFET is turned on (CTL input active).

Undervoltage Lockout

Undervoltage lockout (UVLO) prevents the output MOSFET from turning on until the input voltage, V_{IN} , exceeds 2.5V typical. After the switch turns on, if V_{IN} drops below 2.3V typical, UVLO shuts off the output MOSFET and the FLG output is set (active low) until V_{IN} drops below 1.5V.

The IMP2505 must be enabled (output switch on) for the undervoltage detection function to operate.

Detailed Descriptions

Open-load Detection

Open-load detection signals the absence of an output load by activating the FLG fault flag. Open-load detection is optional and requires external components. Connecting a high-value pull-up resistor (typically 100k Ω) between IN and OUT enables the open-load detection feature.

If there is no output load, a high output voltage (typically >1V) and sets the FLG flag. Under normal conditions, the low resistance of a typical load pulls OUT low.

Open load detection operates only when the output MOSFET is off.

The open-load detection feature is NOT available on the IMP2505-1/-2 versions.

Part Number	CTL Enable Logic Polarity	Open-Load Detection Function
IMP2505	Active-HIGH	Yes
IMP2505-1	Active-HIGH	No
IMP2505-2	Active-LOW	No
IMP2505-3	Active-LOW	Yes

2505_106.eps

Supply Filtering

A 0.1 μ F to 1 μ F bypass capacitor from IN to GND is recommended to control supply transients. Without a bypass capacitor, an output short may cause ringing on the input.

Input transients must not exceed the absolute maximum supply voltage ($V_{IN(max)} = 7.5V$).

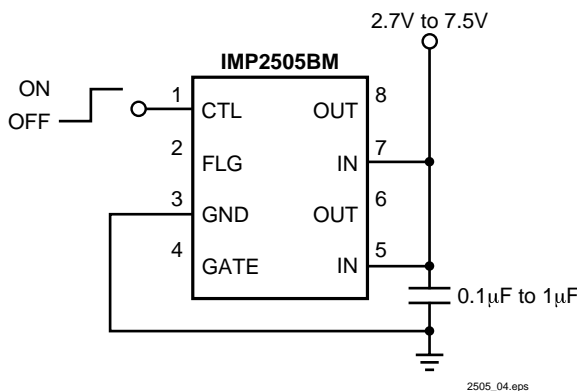

2505_04.eps

Figure 1. Supply Bypassing

Gate Control

The gate control circuit charges the output MOSFET gate from the charge pump output or discharges the MOSFET gate to ground as determined by CTL or by the thermal shutdown and undervoltage lockout circuits.

An external capacitor may be connected to the IMP2505 GATE pin to increase rise time. This will slow the output MOSFET turn-on. Since this pin connects to the MOSFET gate, use ESD precautions.

Leakage resistance at GATE may increase turn-on times.

INPUT and OUTPUT

Current flows through the switch from IN to OUT. IN is the drain and OUT is the source of the N-channel MOSFET switch. IN also supplies power to the internal logic and control circuits.

Application Information

Control Input

CTL must be driven HIGH or LOW, or be pulled HIGH or LOW for a clearly defined input. Floating the input may cause unpredictable operation. Add a diode clamp if negative spikes may occur. See *Figure 2*.

Open-Load Detection

Open-load detection is available only on the IMP2505 and IMP2505-3. For USB applications, the open-load detection feature is not included (IMP2505-1 or -2 versions).

When the output switch is off, the optional open-load detection resistor supplies a small pull-up current to the load. (A 100k Ω resistor will draw 50mA from a 5V supply.) Normally, the load dominates, pulling OUT LOW. If load is absent, the pull-up resistor pulls OUT HIGH, activating the fault flag if CTL is OFF.

When a load is switched off with CTL, capacitance on the output may cause the open-load function to pull the flag low until the capacitor is discharged below approximately 2.4V. Omit the pull-up resistor when open load detection is not required. This will minimize off-state supply current.

Application Information

Power Bus Switch

The IMP2505 family features a MOSFET reverse current flow prevention circuit. This prevents current from flowing backwards (from OUT to IN) when CTL is disabled as long as V_{IN} is above UVLO minimum. In *Figure 2*, when Switch A is on and Switch B is off, this feature prevents current flow from the load (5V) backward through Switch B to the 3.3V supply.

FLG will be active (LOW) on any switch that is off whenever the load voltage is greater than the open load threshold (approximately 1V) except for IMP2505-1 and IMP2505-2.

Hot Plug-In Applications (Soft-Start)

The IMP2505 will protect the socket-side and card-side of a supply circuit from transients caused by a capacitive load connection, connected to an active supply.

The switch presents a high impedance when off, and slowly becomes a low impedance as it turns on. This reduces the inrush current and voltage drop caused by changing current.

A gate capacitor may be added to the IMP2505 to slow the turn on time even more, reducing the inrush current. Undervoltage lockout insures that each time the card is removed and $V_{IN} = 0$ that the gate of the output switch is discharged to zero volts. A controlled turn-on is executed each time a board is plugged in, even with multiple insertions.

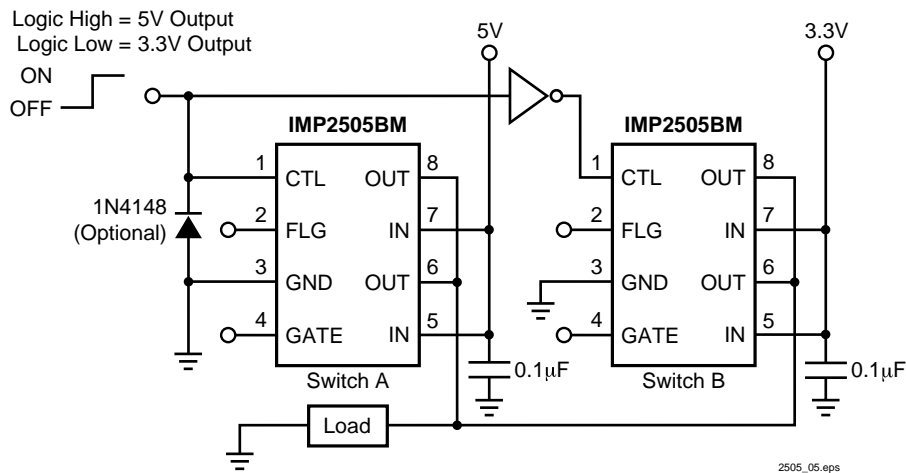

Figure 2. 5V/3.3V Switch Concept

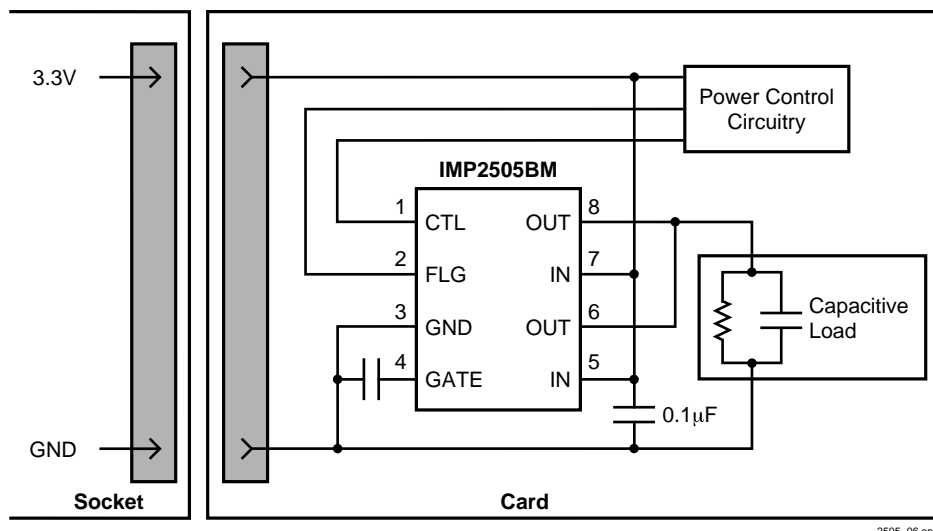
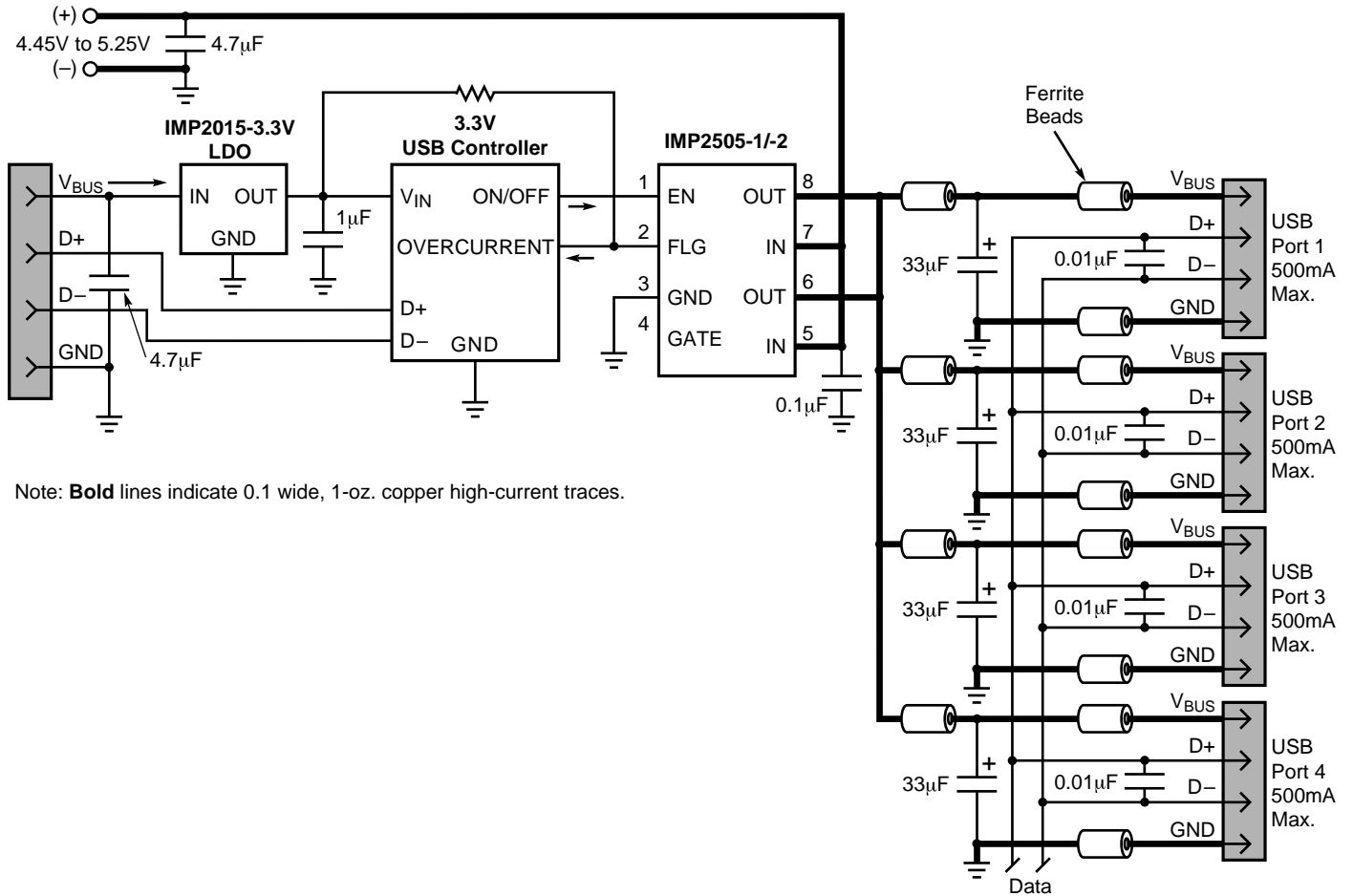

Figure 3. Hot Plug-In Concept

Application Information

USB Ganged Port Switching

Figure 4 shows a low cost implementation of a four-port, self-powered USB hub using ganged port switching.



2505_07.eps

Figure 4. Ganged Port Switching Self-Powered Hub

Package Dimensions

Plastic DIP (8-Pin)

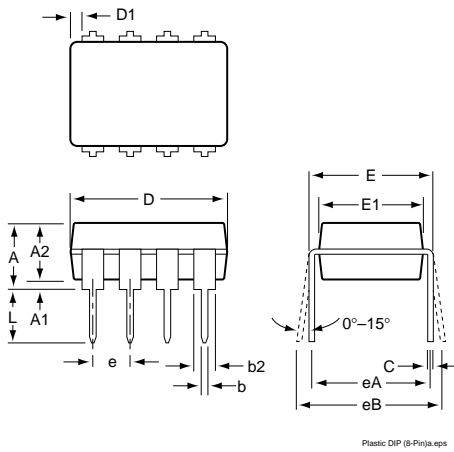

SO (8-Pin)

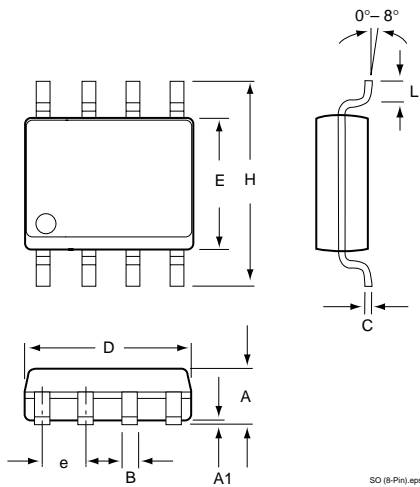

	Inches		Millimeters	
	Min	Max	Min	Max
Plastic DIP (8-Pin)*				
A	—	0.210	—	5.33
A1	0.015	—	0.38	—
A2	0.115	0.195	2.92	4.95
b	0.014	0.022	0.36	0.56
b2	0.045	0.070	1.14	1.78
b3	0.030	0.045	0.80	1.14
D	0.355	0.400	9.02	10.16
D1	0.005	—	0.13	—
E	0.300	0.325	7.62	8.26
E1	0.240	0.280	6.10	7.11
e	0.100	—	2.54	
eA	0.300	—	7.62	
eB	—	0.430	—	10.92
eC	—	0.060	—	—
L	0.115	0.150	2.92	3.81
SO (8-Pin)**				
A	0.053	0.069	1.35	1.75
A1	0.004	0.010	0.10	0.25
B	0.013	0.020	0.33	0.51
C	0.007	0.010	0.19	0.25
e	0.050		1.27	
E	0.150	0.157	3.80	4.00
H	0.228	0.244	5.80	6.20
L	0.016	0.050	0.40	1.27
D	0.189	0.197	4.80	5.00

* JEDEC Drawing MS-001BA

** JEDEC Drawing MS-012AA